



Winkelköpfe

Angle Head

Tête à renvoi d'angle

Açılı Kafa

INHALTSVERZEICHNIS / INDEX

Seite / Page

Slim 1 typ - ER11 spannfutter
Slim 1 type - ER11 collect chuck
Slim 1 type - ER11 mandrin à pincés
Slim 1 tipi - ER11 pens başlığı

7.01 - 7.02

Slim 2 typ - ER8 spannfutter
Slim 2 type - ER8 collect chuck
Slim 2 type - ER8 mandrin à pincés
Slim 2 tipi - ER8 pens başlığı

7.03 - 7.04

S typ - ER16 spannfutter
S type - ER16 collect chuck
S type - ER16 mandrin à pincés
S tipi - ER16 pens başlığı

7.05 - 7.06

S typ - ER16 short doppelseitig spannfutter
S type - ER16 short double-sided collet chuck
S type - ER16 short double face mandrin à pincés
S tipi - ER16 short çift taraflı pens başlığı

7.07 - 7.08

S typ - ER25 spannfutter
S type - ER25 collect chuck
S type - ER25 mandrin à pincés
S tipi - ER25 pens başlığı

7.09 - 7.10

S typ - KMA16 quernut-aufsteckdorne
S type - KMA16 shell mill holder
S type - KMA16 porte-fraises à surfacer
S tipi - KMA16 alın kamalı malafa

7.11 - 7.12

S typ - ER32 short spannfutter
S type - ER32 short collet chuck
S type - ER32 short mandrin à pincés
S tipi - ER32 short pens başlığı

7.13 - 7.14

M typ - ER40 spannfutter
M type - ER40 collect chuck
M type - ER40 mandrin à pincés
M tipi - ER40 pens başlığı

7.15 - 7.16

M typ - ISO30 adapter / reduzierungen
M type - ISO30 reduction sleeves
M type - ISO30 douilles de réduction
M tipi - ISO30 çektirme civatalı redüksiyon

7.17 - 7.18

M typ - KMA22 quernut-aufsteckdorne
M type - KMA22 shell mill holder
M type - KMA22 porte-fraises à surfacer
M tipi - KMA22 alın kamalı malafa

7.19 - 7.20

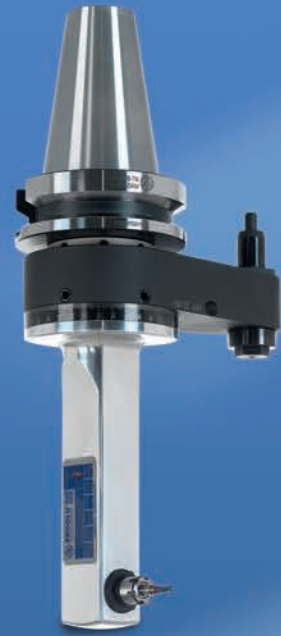

ANGLE HEAD
Winkelköpfe



Winkelköpfe Design und Information

Angled head design and information

Tête à renvoi d'angle Design et information

Açılı kafa tasarımı ve bilgilendirmesi





Kegel-typen / Cone types / Types de cônes / Konik tipleri



SK DIN ISO 7388-1
(DIN 69871)



MAS 403 BT
(JIS B 6339)



HSK
(DIN 69893)



EPS
(ISO 26623-1)

- Alle kegel typen und normen sind verfügbare. Spezieller kegel kann nach bestellung hergestellt werden.
- All conical types and norms are available. Special cone can be produced according to order.
- Tous les types coniques et les normes sont disponibles. Le cône spécial peut être produit selon l'ordre.
- Tüm konik tipleri ve normları mevcuttur. Siparişe göre özel konik üretilebilir.

Drehmomentarm typen / Torque arm types / Types de bras de couple / Tork kolu tipleri



Standart drehmomentarm
Standart torque arm
Bras de couple standart
Standart tork kolu

- Automatischer werkzeugwechsel kann ebenfalls verwendet werden.
- Automatic tool change can also be used.
- Le changement automatique d'outil peut également être utilisé.
- Otomatik takım değiştirmede kullanılabilir.



Drei-stift drehmomentarm
Three-pin torque arm
Bras de couple à trois broches
3 pimli tork kolu

- Für manuellen betrieb.
- For manual operation.
- Pour un fonctionnement manuel.
- Manuel kullanım içindir.

- Spezieller drehmomentarm kann nach bestellung hergestellt werden.
- Special torque arm can be produced according to order.
- Le bras de couple spécial peut être produit selon l'ordre.
- Siparişe göre özel tork kolu üretilebilir.

Körpertypen / Body Types / Types de corps / Gövde Tipleri



M Type



S Type

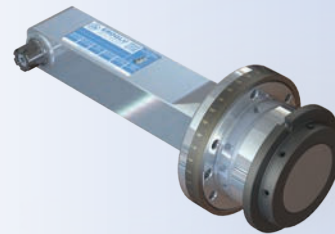

Slim Type

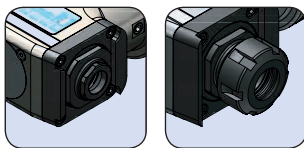

ER32 Short

ER40

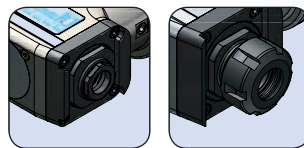

ER16 Short

ER16

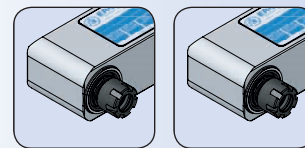

ER11

ER8

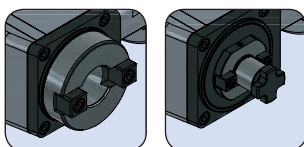

ISO30

KMA22

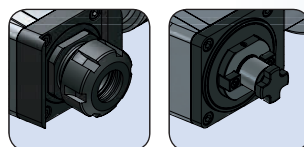

ER25

KMA16

- Spezieller futter kann nach bestellung hergestellt werden.
- Special chuck can be produced according to order.
- Le mandrin spécial peut être produit selon l'ordre.
- Siparişe göre özel tutucu üretilebilir.



Winkelköpfe 90° Slim 1 Typ - ER11 Spannfutter - Standard Drehmomentarm

Angle Head 90° Slim 1 Type - ER11 Collet Chuck - Standard Torque Arm

Tête à renvoi d'angle 90° Slim 1 Type - ER11 Mandrin à pinces -
Bras de couple standard

Açılı Kafa 90° Slim 1 Tipi - ER11 Pens Başlığı - Standart Tork Kolu

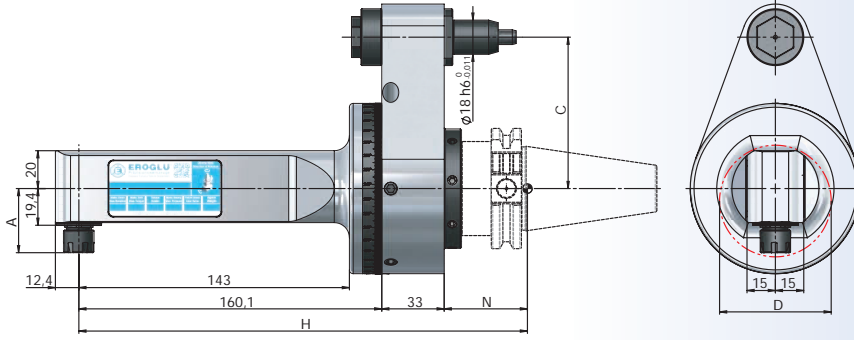

Bestell-Nr. Order Nr. Reference Sipariş Nr.	Kegel Shanks Cônes Konik	Spannbereich Capacity Capacité Kapasite	A	H	N	D	C	Kg	Euro
new 302.RASL1.E11.160.C65	SK 30	ER11 (1-7)	34	244,7	51,6	59	65	2,91	
new 402.RASL1.E11.160.C65	SK 40	ER11 (1-7)	34	244,7	51,6	59	65	3,42	
new 402.RASL1.E11.160.C80	SK 40	ER11 (1-7)	34	244,7	51,6	59	80	3,49	
new 502.RASL1.E11.160.C80	SK 50	ER11 (1-7)	34	229,7	36,6	59	80	5,29	
new 502.RASL1.E11.160.C110	SK 50	ER11 (1-7)	34	229,7	36,6	59	110	5,45	
new 402ERP.RASL1.E11.160.C65	SK 40-ERP	ER11 (1-7)	34	244,7	51,6	59	65	3,45	
new 402ERP.RASL1.E11.160.C80	SK 40-ERP	ER11 (1-7)	34	244,7	51,6	59	80	3,52	
new 502ERP.RASL1.E11.160.C80	SK 50-ERP	ER11 (1-7)	34	229,7	36,6	59	80	5,33	
new 502ERP.RASL1.E11.160.C110	SK 50-ERP	ER11 (1-7)	34	229,7	36,6	59	110	5,49	
new 305.RASL1.E11.160.C65	BT 30	ER11 (1-7)	34	235,7	42,6	59	65	2,94	
new 405.RASL1.E11.160.C65	BT 40	ER11 (1-7)	34	244,7	51,6	59	65	3,70	
new 405.RASL1.E11.160.C80	BT 40	ER11 (1-7)	34	244,7	51,6	59	80	3,77	
new 505.RASL1.E11.160.C80	BT 50	ER11 (1-7)	34	243,8	50,7	59	80	6,09	
new 505.RASL1.E11.160.C110	BT 50	ER11 (1-7)	34	243,8	50,7	59	110	6,25	
new 405ERP.RASL1.E11.160.C65	BT 40-ERP	ER11 (1-7)	34	244,7	51,6	59	65	3,71	
new 405ERP.RASL1.E11.160.C80	BT 40-ERP	ER11 (1-7)	34	244,7	51,6	59	80	3,78	
new 505ERP.RASL1.E11.160.C80	BT 50-ERP	ER11 (1-7)	34	243,8	50,7	59	80	6,13	
new 505ERP.RASL1.E11.160.C110	BT 50-ERP	ER11 (1-7)	34	243,8	50,7	59	110	6,29	
new A63.RASL1.E11.160.C65	HSK-A 63	ER11 (1-7)	34	244,7	51,6	59	65	3,28	
new A63.RASL1.E11.160.C80	HSK-A 63	ER11 (1-7)	34	244,7	51,6	59	80	3,35	
new A100.RASL1.E11.160.C80	HSK-A 100	ER11 (1-7)	34	244,7	51,6	59	80	4,61	
new A100.RASL1.E11.160.C110	HSK-A 100	ER11 (1-7)	34	244,7	51,6	59	110	4,77	
new EP6.RASL1.E11.160.C65	EPS 63	ER11 (1-7)	34	216,7	23,6	59	65	3,27	
new EP6.RASL1.E11.160.C80	EPS 63	ER11 (1-7)	34	216,7	23,6	59	80	3,34	

Zubehör / Accessories / Accessoires / Yedekler



Spannzangen System ER
Collets System ER
Pincés de serrage System ER
Pens ER



Spannmutter Mini
Nut Mini
Écrou mini
Mini kapak



Rollenschlüssel für Spannmutter
Roller Bearing Wrenches
Cles à rouleaux
Bilyalı Kapak Sıkma Anahtar



Spannschlüssel ER
Wrench ER
Clé de serrage
Anahtar ER



Winkelköpfe 90° Slim 1 Typ - ER11 Spannfutter - Drei-Stift Drehmomentarm

Angle Head 90° Slim 1 Type - ER11 Collet Chuck - Three-pin torque arm

Tête à renvoi d'angle 90° Slim 1 Type - ER11 Mandrin à pinces -
Bras de couple à trois broches

Açılı Kafa 90° Slim 1 Tipi - ER11 Pens Başlığı - Üç Pimli Tork Kolu

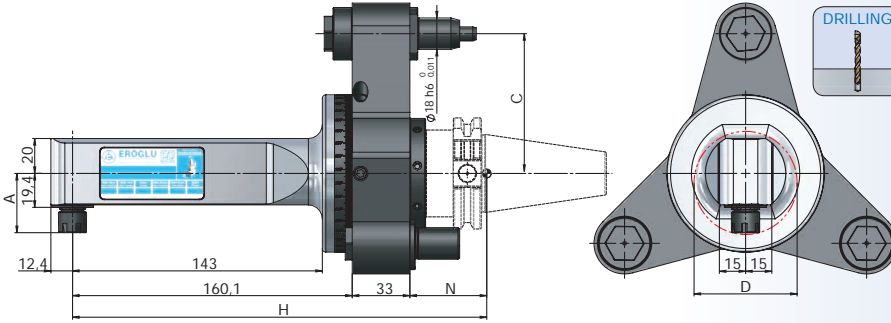

Bestell-Nr. Order Nr. Reference Sipariş Nr.	Konik	Spannbereich Capacity Capacité Kapasite	A	H	N	D	C	Kg	Euro
new 302.RASL1.E11.160.C65.3	SK 30	ER11 (1-7)	34	244,7	51,6	59	65	4,37	
new 402.RASL1.E11.160.C65.3	SK 40	ER11 (1-7)	34	244,7	51,6	59	65	4,88	
new 402.RASL1.E11.160.C80.3	SK 40	ER11 (1-7)	34	244,7	51,6	59	80	5,36	
new 502.RASL1.E11.160.C80.3	SK 50	ER11 (1-7)	34	229,7	36,6	59	80	7,16	
new 502.RASL1.E11.160.C110.3	SK 50	ER11 (1-7)	34	229,7	36,6	59	110	8,39	
new 402ERP.RASL1.E11.160.C65.3	SK 40-ERP	ER11 (1-7)	34	244,7	51,6	59	65	4,40	
new 402ERP.RASL1.E11.160.C80.3	SK 40-ERP	ER11 (1-7)	34	244,7	51,6	59	80	4,91	
new 502ERP.RASL1.E11.160.C80.3	SK 50-ERP	ER11 (1-7)	34	229,7	36,6	59	80	7,20	
new 502ERP.RASL1.E11.160.C110.3	SK 50-ERP	ER11 (1-7)	34	229,7	36,6	59	110	8,43	
new 305.RASL1.E11.160.C65.3	BT 30	ER11 (1-7)	34	235,7	42,6	59	65	4,40	
new 405.RASL1.E11.160.C65.3	BT 40	ER11 (1-7)	34	244,7	51,6	59	65	5,16	
new 405.RASL1.E11.160.C80.3	BT 40	ER11 (1-7)	34	244,7	51,6	59	80	5,64	
new 505.RASL1.E11.160.C80.3	BT 50	ER11 (1-7)	34	243,8	50,7	59	80	7,96	
new 505.RASL1.E11.160.C110.3	BT 50	ER11 (1-7)	34	243,8	50,7	59	110	9,19	
new 405ERP.RASL1.E11.160.C65.3	BT 40-ERP	ER11 (1-7)	34	244,7	51,6	59	65	5,17	
new 405ERP.RASL1.E11.160.C80.3	BT 40-ERP	ER11 (1-7)	34	244,7	51,6	59	80	5,65	
new 505ERP.RASL1.E11.160.C80.3	BT 50-ERP	ER11 (1-7)	34	243,8	50,7	59	80	8,00	
new 505ERP.RASL1.E11.160.C110.3	BT 50-ERP	ER11 (1-7)	34	243,8	50,7	59	110	9,23	
new A63.RASL1.E11.160.C65.3	HSK-A 63	ER11 (1-7)	34	244,7	51,6	59	65	4,74	
new A63.RASL1.E11.160.C80.3	HSK-A 63	ER11 (1-7)	34	244,7	51,6	59	80	5,22	
new A100.RASL1.E11.160.C80.3	HSK-A 100	ER11 (1-7)	34	244,7	51,6	59	80	6,48	
new A100.RASL1.E11.160.C110.3	HSK-A 100	ER11 (1-7)	34	244,7	51,6	59	110	7,71	
new EP6.RASL1.E11.160.C65.3	EPS 63	ER11 (1-7)	34	216,7	23,6	59	65	4,73	
new EP6.RASL1.E11.160.C80.3	EPS 63	ER11 (1-7)	34	216,7	23,6	59	80	5,21	

Zubehör / Accessories / Accessoires / Yedekler



Spannzangen System ER
Collets System ER
Pinces de serrage System ER
Pens ER



Spannmutter Mini
Nut Mini
Écrou Mini
Mini kapak



Rollenschlüssel für Spannmutter
Roller Bearing Wrenches
Cles à rouleaux
Bilyalı Kapak Sıkma Anahtar



Spannschlüssel ER
Wrench ER
Clé de serrage
Anahtar ER



Winkelköpfe 90° Slim 2 Typ - ER8 Spannfutter - Standard Drehmomentarm

Angle Head 90° Slim 2 Type - ER8 Collet Chuck - Standard Torque Arm

Tête à renvoi d'angle 90° Slim 2 Type - ER8 Mandrin à pinces -
Bras de couple standard

Açılı Kafa 90° Slim 2 Tipi - ER8 Pens Başlığı - Standart Tork Kolu

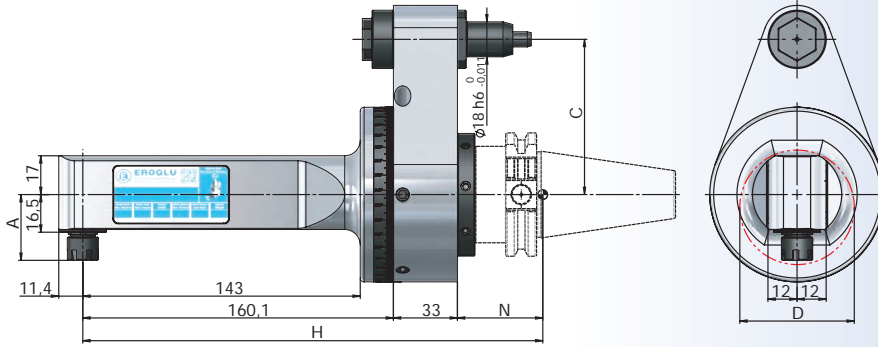

Bestell-Nr. Order Nr. Reference Sipariş Nr.	Kegel Shanks Cônes Konik	Spannbereich Capacity Capacité Kapasite	A	H	N	D	C	Kg	Euro
new 302.RASL2.E8.160.C65	SK 30	ER8 (0,5-5)	30,5	244,7	51,6	53	65	2,97	
new 402.RASL2.E8.160.C65	SK 40	ER8 (0,5-5)	30,5	244,7	51,6	53	65	3,48	
new 402.RASL2.E8.160.C80	SK 40	ER8 (0,5-5)	30,5	244,7	51,6	53	80	3,55	
new 502.RASL2.E8.160.C80	SK 50	ER8 (0,5-5)	30,5	229,7	36,6	53	80	5,35	
new 502.RASL2.E8.160.C110	SK 50	ER8 (0,5-5)	30,5	229,7	36,6	53	110	5,51	
new 402ERP.RASL2.E8.160.C65	SK 40-ERP	ER8 (0,5-5)	30,5	244,7	51,6	53	65	3,51	
new 402ERP.RASL2.E8.160.C80	SK 40-ERP	ER8 (0,5-5)	30,5	244,7	51,6	53	80	3,58	
new 502ERP.RASL2.E8.160.C80	SK 50-ERP	ER8 (0,5-5)	30,5	229,7	36,6	53	80	5,39	
new 502ERP.RASL2.E8.160.C110	SK 50-ERP	ER8 (0,5-5)	30,5	229,7	36,6	53	110	5,55	
new 305.RASL2.E8.160.C65	BT 30	ER8 (0,5-5)	30,5	235,7	42,6	53	65	3,00	
new 405.RASL2.E8.160.C65	BT 40	ER8 (0,5-5)	30,5	244,7	51,6	53	65	3,76	
new 405.RASL2.E8.160.C80	BT 40	ER8 (0,5-5)	30,5	244,7	51,6	53	80	3,83	
new 505.RASL2.E8.160.C80	BT 50	ER8 (0,5-5)	30,5	243,8	50,7	53	80	6,15	
new 505.RASL2.E8.160.C110	BT 50	ER8 (0,5-5)	30,5	243,8	50,7	53	110	6,31	
new 405ERP.RASL2.E8.160.C65	BT 40-ERP	ER8 (0,5-5)	30,5	244,7	51,6	53	65	3,77	
new 405ERP.RASL2.E8.160.C80	BT 40-ERP	ER8 (0,5-5)	30,5	244,7	51,6	53	80	3,84	
new 505ERP.RASL2.E8.160.C80	BT 50-ERP	ER8 (0,5-5)	30,5	243,8	50,7	53	80	6,19	
new 505ERP.RASL2.E8.160.C110	BT 50-ERP	ER8 (0,5-5)	30,5	243,8	50,7	53	110	6,35	
new A63.RASL2.E8.160.C65	HSK-A 63	ER8 (0,5-5)	30,5	244,7	51,6	53	65	3,34	
new A63.RASL2.E8.160.C80	HSK-A 63	ER8 (0,5-5)	30,5	244,7	51,6	53	80	3,41	
new A100.RASL2.E8.160.C80	HSK-A 100	ER8 (0,5-5)	30,5	244,7	51,6	53	80	4,67	
new A100.RASL2.E8.160.C110	HSK-A 100	ER8 (0,5-5)	30,5	244,7	51,6	53	110	4,83	
new EP6.RASL2.E8.160.C65	EPS 63	ER8 (0,5-5)	30,5	216,7	23,6	53	65	3,33	
new EP6.RASL2.E8.160.C80	EPS 63	ER8 (0,5-5)	30,5	216,7	23,6	53	80	3,40	

Zubehör / Accessories / Accessoires / Yedekler





Winkelköpfe 90° Slim 2 Typ - ER8 Spannfutter - Drei-Stift Drehmomentarm

Angle Head 90° Slim 2 Type - ER8 Collet Chuck - Three-pin torque arm

Tête à renvoi d'angle 90° Slim 2 Type - ER8 Mandrin à pinces -
Bras de couple à trois broches

Açılı Kafa 90° Slim 2 Tipi - ER8 Pens Başlığı - Üç Pimli Tork Kolu

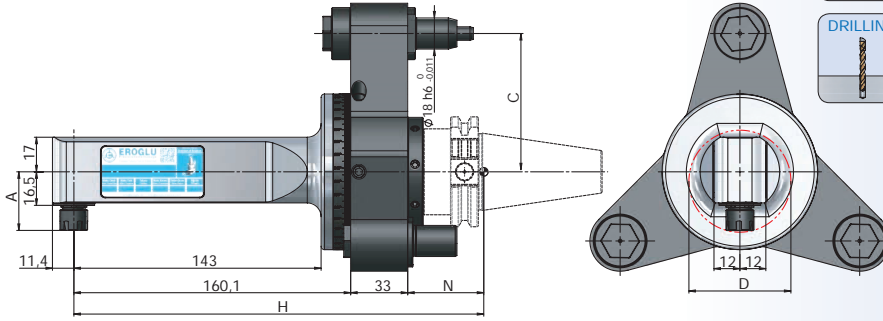

Bestell-Nr. Order Nr. Reference Sipariş Nr.	Kegel Shanks Cônes Konik	Spannbereich Capacity Capacité Kapasite	A	H	N	D	C	Kg	Euro
new 302.RASL2.E8.160.C65.3	SK 30	ER8 (0,5-5)	30,5	244,7	51,6	53	65	4,43	
new 402.RASL2.E8.160.C65.3	SK 40	ER8 (0,5-5)	30,5	244,7	51,6	53	65	4,94	
new 402.RASL2.E8.160.C80.3	SK 40	ER8 (0,5-5)	30,5	244,7	51,6	53	80	5,42	
new 502.RASL2.E8.160.C80.3	SK 50	ER8 (0,5-5)	30,5	229,7	36,6	53	80	7,22	
new 502.RASL2.E8.160.C110.3	SK 50	ER8 (0,5-5)	30,5	229,7	36,6	53	110	8,45	
new 402ERP.RASL2.E8.160.C65.3	SK 40-ERP	ER8 (0,5-5)	30,5	244,7	51,6	53	65	4,97	
new 402ERP.RASL2.E8.160.C80.3	SK 40-ERP	ER8 (0,5-5)	30,5	244,7	51,6	53	80	5,45	
new 502ERP.RASL2.E8.160.C80.3	SK 50-ERP	ER8 (0,5-5)	30,5	229,7	36,6	53	80	7,26	
new 502ERP.RASL2.E8.160.C110.3	SK 50-ERP	ER8 (0,5-5)	30,5	229,7	36,6	53	110	8,49	
new 305.RASL2.E8.160.C65.3	BT 30	ER8 (0,5-5)	30,5	235,7	42,6	53	65	4,46	
new 405.RASL2.E8.160.C65.3	BT 40	ER8 (0,5-5)	30,5	244,7	51,6	53	65	5,22	
new 405.RASL2.E8.160.C80.3	BT 40	ER8 (0,5-5)	30,5	244,7	51,6	53	80	5,70	
new 505.RASL2.E8.160.C80.3	BT 50	ER8 (0,5-5)	30,5	243,8	50,7	53	80	8,02	
new 505.RASL2.E8.160.C110.3	BT 50	ER8 (0,5-5)	30,5	243,8	50,7	53	110	9,25	
new 405ERP.RASL2.E8.160.C65.3	BT 40-ERP	ER8 (0,5-5)	30,5	244,7	51,6	53	65	4,47	
new 405ERP.RASL2.E8.160.C80.3	BT 40-ERP	ER8 (0,5-5)	30,5	244,7	51,6	53	80	5,23	
new 505ERP.RASL2.E8.160.C80.3	BT 50-ERP	ER8 (0,5-5)	30,5	243,8	50,7	53	80	8,06	
new 505ERP.RASL2.E8.160.C110.3	BT 50-ERP	ER8 (0,5-5)	30,5	243,8	50,7	53	110	9,29	
new A63.RASL2.E8.160.C65.3	HSK-A 63	ER8 (0,5-5)	30,5	244,7	51,6	53	65	4,80	
new A63.RASL2.E8.160.C80.3	HSK-A 63	ER8 (0,5-5)	30,5	244,7	51,6	53	80	5,28	
new A100.RASL2.E8.160.C80.3	HSK-A 100	ER8 (0,5-5)	30,5	244,7	51,6	53	80	6,54	
new A100.RASL2.E8.160.C110.3	HSK-A 100	ER8 (0,5-5)	30,5	244,7	51,6	53	110	7,77	
new EP6.RASL2.E8.160.C65.3	EPS 63	ER8 (0,5-5)	30,5	216,7	23,6	53	65	4,79	
new EP6.RASL2.E8.160.C80.3	EPS 63	ER8 (0,5-5)	30,5	216,7	23,6	53	80	5,27	

Zubehör / Accessories / Accessoires / Yedekler



Spannzangen System ER
Collets System ER
Pincés de serrage System ER
Pens ER



Spannmutter Mini
Nut Mini
Écrou mini
Mini kapak



Rollenschlüssel für Spannmutter
Roller Bearing Wrenches
Cles à rouleaux
Bilyalı Kapak Sıkma Anahtar



Spannschlüssel ER
Wrench ER
Clé de serrage
Anahtar ER



Winkelköpfe 90° S Typ - ER16 Spannutter - Standard Drehmomentarm

Angle Head 90° S Type - ER16 Collet Chuck - Standard Torque Arm

Tête à renvoi d'angle 90° S Type - ER16 Mandrin à pinces -
Bras de couple standard

Açılı Kafa 90° S Tipi - ER16 Pens Başlığı - Standart Tork Kolu

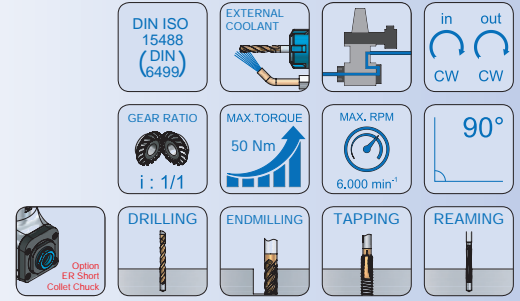
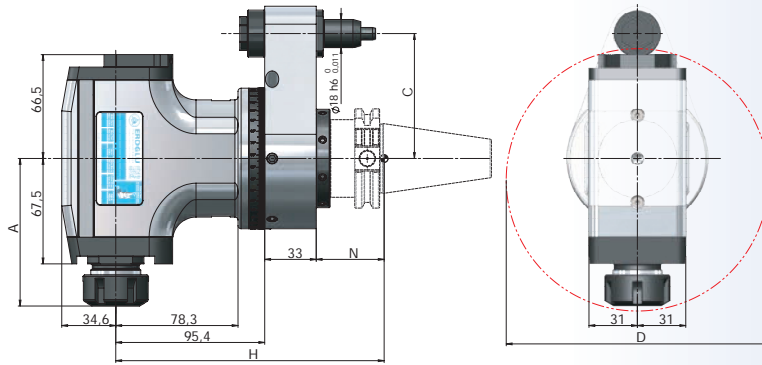

Bestell-Nr. Order Nr. Reference Sipariş Nr.	Kegel Shanks Cônes Konik	Spannbereich Capacity Capacité Kapasite	A	H	N	D	C	Kg	Euro
new 302.RAS.E16.95.C65	SK 30	ER16 (1-10)	87,5	180	51,6	160	65	5,19	
new 402.RAS.E16.95.C65	SK 40	ER16 (1-10)	87,5	180	51,6	160	65	5,70	
new 402.RAS.E16.95.C80	SK 40	ER16 (1-10)	87,5	180	51,6	160	80	5,77	
new 502.RAS.E16.95.C80	SK 50	ER16 (1-10)	87,5	165	36,6	160	80	7,40	
new 502.RAS.E16.95.C110	SK 50	ER16 (1-10)	87,5	165	36,6	160	110	7,56	
new 402ERP.RAS.E16.95.C65	SK 40-ERP	ER16 (1-10)	87,5	180	51,6	160	65	5,73	
new 402ERP.RAS.E16.95.C80	SK 40-ERP	ER16 (1-10)	87,5	180	51,6	160	80	5,80	
new 502ERP.RAS.E16.95.C80	SK 50-ERP	ER16 (1-10)	87,5	165	36,6	160	80	7,44	
new 502ERP.RAS.E16.95.C110	SK 50-ERP	ER16 (1-10)	87,5	165	36,6	160	110	7,60	
new 305.RAS.E16.95.C65	BT 30	ER16 (1-10)	87,5	171	42,6	160	65	5,05	
new 405.RAS.E16.95.C65	BT 40	ER16 (1-10)	87,5	180	51,6	160	65	5,81	
new 405.RAS.E16.95.C80	BT 40	ER16 (1-10)	87,5	180	51,6	160	80	5,88	
new 505.RAS.E16.95.C80	BT 50	ER16 (1-10)	87,5	179,1	50,7	160	80	8,30	
new 505.RAS.E16.95.C110	BT 50	ER16 (1-10)	87,5	179,1	50,7	160	110	8,46	
new 405ERP.RAS.E16.95.C65	BT 40-ERP	ER16 (1-10)	87,5	180	51,6	160	65	5,82	
new 405ERP.RAS.E16.95.C80	BT 40-ERP	ER16 (1-10)	87,5	180	51,6	160	80	5,89	
new 505ERP.RAS.E16.95.C80	BT 50-ERP	ER16 (1-10)	87,5	179,1	50,7	160	80	8,34	
new 505ERP.RAS.E16.95.C110	BT 50-ERP	ER16 (1-10)	87,5	179,1	50,7	160	110	8,50	
new A63.RAS.E16.95.C65	HSK-A 63	ER16 (1-10)	87,5	180	51,6	160	65	5,41	
new A63.RAS.E16.95.C80	HSK-A 63	ER16 (1-10)	87,5	180	51,6	160	80	5,48	
new A100.RAS.E16.95.C80	HSK-A 100	ER16 (1-10)	87,5	180	51,6	160	80	6,88	
new A100.RAS.E16.95.C110	HSK-A 100	ER16 (1-10)	87,5	180	51,6	160	110	7,04	
new EP6.RAS.E16.95.C65	EPS 63	ER16 (1-10)	87,5	152	23,6	160	65	5,38	
new EP6.RAS.E16.95.C80	EPS 63	ER16 (1-10)	87,5	152	23,6	160	80	5,45	

Zubehör / Accessories / Accessoires / Yedekler

DIN ISO
15488



10.11 - 10.18

Spannzangen System ER
Collets System ER
Pincés de serrage System ER
Pens ER

DIN ISO
15488



10.25 - 10.26

Spannmutter ER
Clamping nuts ER
Écrou de serrage ER
Pens kapağı ER



10.48

Spannschlüssel ER
Wrench ER
Clé de serrage
Anahtar ER



10.47

AA Schlüssel
AA Wrench
Clé AA
AA Anahtar



Winkelköpfe 90° S Typ - ER16 Spannfutter - Drei-Stift Drehmomentarm

Angle Head 90° S Type - ER16 Collet Chuck - Three-pin torque arm

Tête à renvoi d'angle 90° S Type - ER16 Mandrin à pinces -
Bras de couple à trois broches

Açılı Kafa 90° S Tipi - ER16 Pens Başlığı - Üç Pimli Tork Kolu

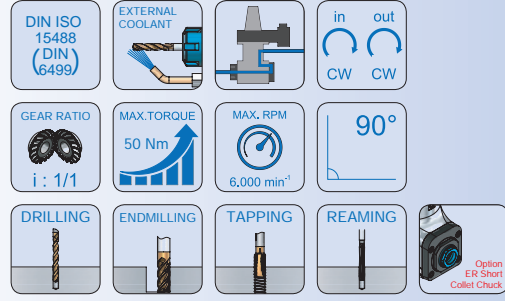
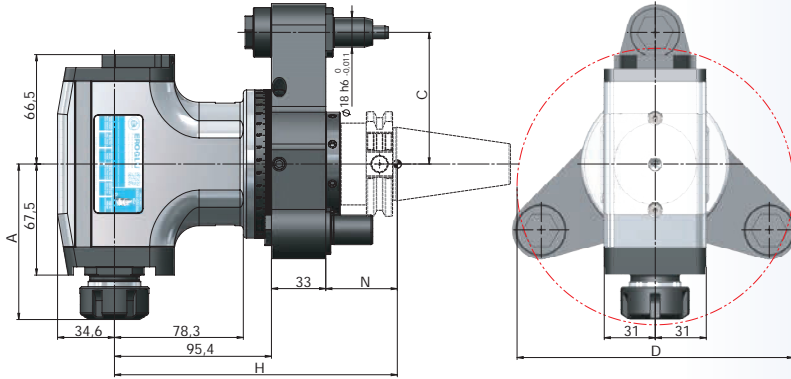

Bestell-Nr. Order Nr. Reference Sipariş Nr.	Kegel Shanks Cônes Konik	Spannbereich Capacity Capacité Kapasite	A	H	N	D	C	Kg	Euro
new 302.RAS.E16.95.C65.3	SK 30	ER16 (1-10)	87,5	180	51,6	160	65	6,65	
new 402.RAS.E16.95.C65.3	SK 40	ER16 (1-10)	87,5	180	51,6	160	65	7,16	
new 402.RAS.E16.95.C80.3	SK 40	ER16 (1-10)	87,5	180	51,6	160	80	7,64	
new 502.RAS.E16.95.C80.3	SK 50	ER16 (1-10)	87,5	165	36,6	160	80	9,27	
new 502.RAS.E16.95.C110.3	SK 50	ER16 (1-10)	87,5	165	36,6	160	110	10,50	
new 402ERP.RAS.E16.95.C65.3	SK 40-ERP	ER16 (1-10)	87,5	180	51,6	160	65	7,19	
new 402ERP.RAS.E16.95.C80.3	SK 40-ERP	ER16 (1-10)	87,5	180	51,6	160	80	7,67	
new 502ERP.RAS.E16.95.C80.3	SK 50-ERP	ER16 (1-10)	87,5	165	36,6	160	80	9,31	
new 502ERP.RAS.E16.95.C110.3	SK 50-ERP	ER16 (1-10)	87,5	165	36,6	160	110	10,54	
new 305.RAS.E16.95.C65.3	BT 30	ER16 (1-10)	87,5	171	42,6	160	65	6,51	
new 405.RAS.E16.95.C65.3	BT 40	ER16 (1-10)	87,5	180	51,6	160	65	7,27	
new 405.RAS.E16.95.C80.3	BT 40	ER16 (1-10)	87,5	180	51,6	160	80	7,75	
new 505.RAS.E16.95.C80.3	BT 50	ER16 (1-10)	87,5	179,1	50,7	160	80	10,17	
new 505.RAS.E16.95.C110.3	BT 50	ER16 (1-10)	87,5	179,1	50,7	160	110	11,40	
new 405ERP.RAS.E16.95.C65.3	BT 40-ERP	ER16 (1-10)	87,5	180	51,6	160	65	7,28	
new 405ERP.RAS.E16.95.C80.3	BT 40-ERP	ER16 (1-10)	87,5	180	51,6	160	80	7,76	
new 505ERP.RAS.E16.95.C80.3	BT 50-ERP	ER16 (1-10)	87,5	179,1	50,7	160	80	10,21	
new 505ERP.RAS.E16.95.C110.3	BT 50-ERP	ER16 (1-10)	87,5	179,1	50,7	160	110	11,44	
new A63.RAS.E16.95.C65.3	HSK-A 63	ER16 (1-10)	87,5	180	51,6	160	65	6,87	
new A63.RAS.E16.95.C80.3	HSK-A 63	ER16 (1-10)	87,5	180	51,6	160	80	7,35	
new A100.RAS.E16.95.C80.3	HSK-A 100	ER16 (1-10)	87,5	180	51,6	160	80	8,75	
new A100.RAS.E16.95.C110.3	HSK-A 100	ER16 (1-10)	87,5	180	51,6	160	110	9,98	
new EP6.RAS.E16.95.C65.3	EPS 63	ER16 (1-10)	87,5	152	23,6	160	65	6,84	
new EP6.RAS.E16.95.C80.3	EPS 63	ER16 (1-10)	87,5	152	23,6	160	80	7,32	

Zubehör / Accessories / Accessoires / Yedekler



Spannzangen System ER
Collets System ER
Pincés de serrage System ER
Pens ER



Spannmutter ER
Clamping nuts ER
Écrou de serrage ER
Pens kapağı ER



Spann Schlüssel ER
Wrench ER
Clé de serrage
Anahtar ER



AA Schlüssel
AA Wrench
Clé AA
AA Anahtar



Winkelköpfe 90° S Typ - ER16 Short Doppelseitig Spannfutter - Standard Drehmomentarm

Angle Head 90° S Type - ER16 Short Double-sided Collet Chuck - Standard Torque Arm

Tête à renvoi d'angle 90° S Type - ER16 Short Double Face Mandrin à pinces - Bras de couple standard

Açılı Kafa 90° S Tipi - ER16 Short Çift Taraflı Pens Başlığı - Standart Tork Kolu

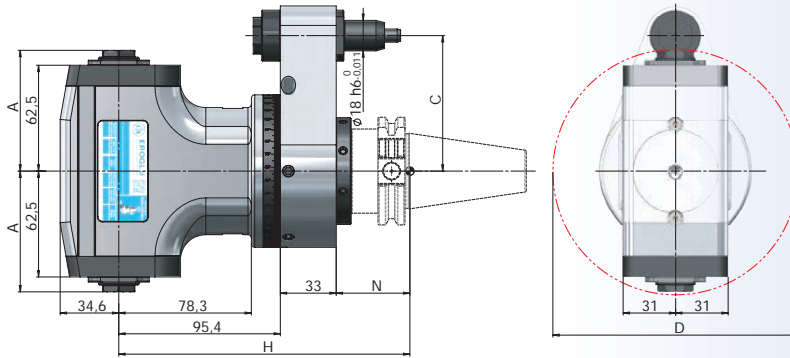

Bestell-Nr. Order Nr. Reference Sipariş Nr.	Kegel Shanks Cônes Konik	Spannbereich Capacity Capacité Kapasite	A	H	N	D	C	Kg	Euro
new 302.RAS.E16SD.95.C65	SK 30	ER16S (1-10)	71	180	51,6	147	65	5,09	
new 402.RAS.E16SD.95.C65	SK 40	ER16S (1-10)	71	180	51,6	147	65	5,60	
new 402.RAS.E16SD.95.C80	SK 40	ER16S (1-10)	71	180	51,6	147	80	5,67	
new 502.RAS.E16SD.95.C80	SK 50	ER16S (1-10)	71	165	36,6	147	80	7,30	
new 502.RAS.E16SD.95.C110	SK 50	ER16S (1-10)	71	165	36,6	147	110	7,46	
new 402ERP.RAS.E16SD.95.C65	SK 40-ERP	ER16S (1-10)	71	180	51,6	147	65	5,63	
new 402ERP.RAS.E16SD.95.C80	SK 40-ERP	ER16S (1-10)	71	180	51,6	147	80	5,70	
new 502ERP.RAS.E16SD.95.C80	SK 50-ERP	ER16S (1-10)	71	165	36,6	147	80	7,34	
new 502ERP.RAS.E16SD.95.C110	SK 50-ERP	ER16S (1-10)	71	165	36,6	147	110	7,50	
new 305.RAS.E16SD.95.C65	BT 30	ER16S (1-10)	71	171	42,6	147	65	4,95	
new 405.RAS.E16SD.95.C65	BT 40	ER16S (1-10)	71	180	51,6	147	65	5,71	
new 405.RAS.E16SD.95.C80	BT 40	ER16S (1-10)	71	180	51,6	147	80	5,78	
new 505.RAS.E16SD.95.C80	BT 50	ER16S (1-10)	71	179,1	50,7	147	80	8,20	
new 505.RAS.E16SD.95.C110	BT 50	ER16S (1-10)	71	179,1	50,7	147	110	8,36	
new 405ERP.RAS.E16SD.95.C65	BT 40-ERP	ER16S (1-10)	71	180	51,6	147	65	5,72	
new 405ERP.RAS.E16SD.95.C80	BT 40-ERP	ER16S (1-10)	71	180	51,6	147	80	5,79	
new 505ERP.RAS.E16SD.95.C80	BT 50-ERP	ER16S (1-10)	71	179,1	50,7	147	80	8,24	
new 505ERP.RAS.E16SD.95.C110	BT 50-ERP	ER16S (1-10)	71	179,1	50,7	147	110	8,40	
new A63.RAS.E16SD.95.C65	HSK-A 63	ER16S (1-10)	71	180	51,6	147	65	5,31	
new A63.RAS.E16SD.95.C80	HSK-A 63	ER16S (1-10)	71	180	51,6	147	80	5,38	
new A100.RAS.E16SD.95.C80	HSK-A 100	ER16S (1-10)	71	180	51,6	147	80	6,78	
new A100.RAS.E16SD.95.C110	HSK-A 100	ER16S (1-10)	71	180	51,6	147	110	6,94	
new EP6.RAS.E16SD.95.C65	EPS 63	ER16S (1-10)	71	152	23,6	147	65	5,28	
new EP6.RAS.E16SD.95.C80	EPS 63	ER16S (1-10)	71	152	23,6	147	80	5,35	

Zubehör / Accessories / Accessoires / Yedekler



Spannzangen System ER
Collets System ER
Pincés de serrage System ER
Pens ER



Spannmutter ER
Clamping nuts ER
Écrou de serrage ER
Pens kapağı ER



Spannschlüssel ER
Wrench ER
Clé de serrage
Anahtar ER



AA Schlüssel
AA Wrench
Clé AA
AA Anahtar



Winkelköpfe 90° S Typ - ER16 Short Doppelseitig Spannutter - Drei-Stift Drehmomentarm

Angle Head 90° S Type - ER16 Short Double-sided Collet Chuck - Three-Pin Torque Arm

Tête à renvoi d'angle 90° S Type - ER16 Short Double Face Mandrin à pinces - Bras de couple à trois broches

Açılı Kafa 90° S Tipi - ER16 Short Çift Taraflı Pens Başlığı - Üç Pimli Tork Kolu

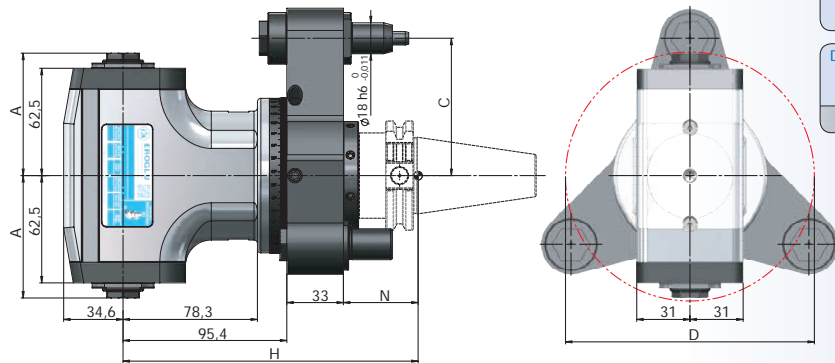

Bestell-Nr. Order Nr. Reference Sipariş Nr.	Kegel Shanks Cônes Konik	Spannbereich Capacity Capacité Kapasite	A	H	N	D	C	Kg	Euro
new 302.RAS.E16SD.95.C65.3	SK 30	ER16S (1-10)	71	180	51,6	147	65	6,55	
new 402.RAS.E16SD.95.C65.3	SK 40	ER16S (1-10)	71	180	51,6	147	65	7,06	
new 402.RAS.E16SD.95.C80.3	SK 40	ER16S (1-10)	71	180	51,6	147	80	7,54	
new 502.RAS.E16SD.95.C80.3	SK 50	ER16S (1-10)	71	165	36,6	147	80	9,17	
new 502.RAS.E16SD.95.C110.3	SK 50	ER16S (1-10)	71	165	36,6	147	110	10,40	
new 402ERP.RAS.E16SD.95.C65.3	SK 40-ERP	ER16S (1-10)	71	180	51,6	147	65	7,09	
new 402ERP.RAS.E16SD.95.C80.3	SK 40-ERP	ER16S (1-10)	71	180	51,6	147	80	7,57	
new 502ERP.RAS.E16SD.95.C80.3	SK 50-ERP	ER16S (1-10)	71	165	36,6	147	80	7,21	
new 502ERP.RAS.E16SD.95.C110.3	SK 50-ERP	ER16S (1-10)	71	165	36,6	147	110	10,44	
new 305.RAS.E16SD.95.C65.3	BT 30	ER16S (1-10)	71	171	42,6	147	65	6,41	
new 405.RAS.E16SD.95.C65.3	BT 40	ER16S (1-10)	71	180	51,6	147	65	7,17	
new 405.RAS.E16SD.95.C80.3	BT 40	ER16S (1-10)	71	180	51,6	147	80	7,65	
new 505.RAS.E16SD.95.C80.3	BT 50	ER16S (1-10)	71	179,1	50,7	147	80	10,07	
new 505.RAS.E16SD.95.C110.3	BT 50	ER16S (1-10)	71	179,1	50,7	147	110	11,30	
new 405ERP.RAS.E16SD.95.C65.3	BT 40-ERP	ER16S (1-10)	71	180	51,6	147	65	7,18	
new 405ERP.RAS.E16SD.95.C80.3	BT 40-ERP	ER16S (1-10)	71	180	51,6	147	80	7,66	
new 505ERP.RAS.E16SD.95.C80.3	BT 50-ERP	ER16S (1-10)	71	179,1	50,7	147	80	10,11	
new 505ERP.RAS.E16SD.95.C110.3	BT 50-ERP	ER16S (1-10)	71	179,1	50,7	147	110	11,34	
new A63.RAS.E16SD.95.C65.3	HSK-A 63	ER16S (1-10)	71	180	51,6	147	65	6,77	
new A63.RAS.E16SD.95.C80.3	HSK-A 63	ER16S (1-10)	71	180	51,6	147	80	7,25	
new A100.RAS.E16SD.95.C80.3	HSK-A 100	ER16S (1-10)	71	180	51,6	147	80	8,65	
new A100.RAS.E16SD.95.C110.3	HSK-A 100	ER16S (1-10)	71	180	51,6	147	110	8,88	
new EP6.RAS.E16SD.95.C65.3	EPS 63	ER16S (1-10)	71	152	23,6	147	65	6,74	
new EP6.RAS.E16SD.95.C80.3	EPS 63	ER16S (1-10)	71	152	23,6	147	80	7,22	

Zubehör / Accessories / Accessoires / Yedekler



Spannzangen System ER
Collets System ER
Pincés de serrage System ER
Pens ER



Spannmutter ER
Clamping nuts ER
Écrou de serrage ER
Pens kapağı ER



Spannschlüssel ER
Wrench ER
Clé de serrage
Anahtar ER



AA Schlüssel
AA Wrench
Clé AA
AA Anahtar



Winkelköpfe 90° S Typ - ER25 Spannfutter - Standard Drehmomentarm

Angle Head 90° S Type - ER25 Collet Chuck - Standard Torque Arm

Tête à renvoi d'angle 90° S Type - ER25 Mandrin à pinces -
Bras de couple standard

Açılı Kafa 90° S Tipi - ER25 Pens Başlığı - Standart Tork Kolu

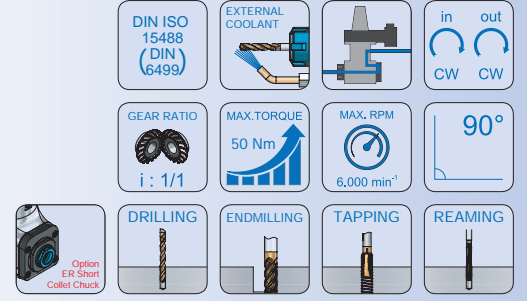
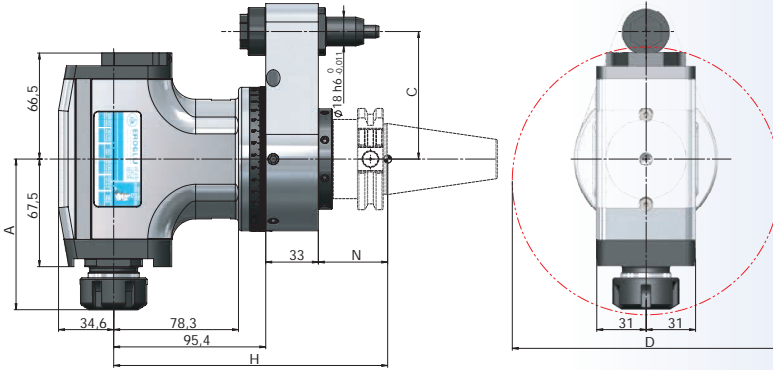

Bestell-Nr. Order Nr. Reference Sipariş Nr.	Kegel Shanks Cônes Konik	Spannbereich Capacity Capacité Kapasite	A	H	N	D	C	Kg	Euro
new 302.RAS.E25.95.C65	SK 30	ER25 (2-16)	94	180	51,6	168	65	5,25	
new 402.RAS.E25.95.C65	SK 40	ER25 (2-16)	94	180	51,6	168	65	5,76	
new 402.RAS.E25.95.C80	SK 40	ER25 (2-16)	94	180	51,6	168	80	5,83	
new 502.RAS.E25.95.C80	SK 50	ER25 (2-16)	94	165	36,6	168	80	7,46	
new 502.RAS.E25.95.C110	SK 50	ER25 (2-16)	94	165	36,6	168	110	7,62	
new 402ERP.RAS.E25.95.C65	SK 40-ERP	ER25 (2-16)	94	180	51,6	168	65	5,79	
new 402ERP.RAS.E25.95.C80	SK 40-ERP	ER25 (2-16)	94	180	51,6	168	80	5,86	
new 502ERP.RAS.E25.95.C80	SK 50-ERP	ER25 (2-16)	94	165	36,6	168	80	7,50	
new 502ERP.RAS.E25.95.C110	SK 50-ERP	ER25 (2-16)	94	165	36,6	168	110	7,66	
new 305.RAS.E25.95.C65	BT 30	ER25 (2-16)	94	171	42,6	168	65	5,11	
new 405.RAS.E25.95.C65	BT 40	ER25 (2-16)	94	180	51,6	168	65	5,87	
new 405.RAS.E25.95.C80	BT 40	ER25 (2-16)	94	180	51,6	168	80	5,94	
new 505.RAS.E25.95.C80	BT 50	ER25 (2-16)	94	179,1	50,7	168	80	8,36	
new 505.RAS.E25.95.C110	BT 50	ER25 (2-16)	94	179,1	50,7	168	110	8,52	
new 405ERP.RAS.E25.95.C65	BT 40-ERP	ER25 (2-16)	94	180	51,6	168	65	5,88	
new 405ERP.RAS.E25.95.C80	BT 40-ERP	ER25 (2-16)	94	180	51,6	168	80	5,95	
new 505ERP.RAS.E25.95.C80	BT 50-ERP	ER25 (2-16)	94	179,1	50,7	168	80	8,40	
new 505ERP.RAS.E25.95.C110	BT 50-ERP	ER25 (2-16)	94	179,1	50,7	168	110	8,56	
new A63.RAS.E25.95.C65	HSK-A 63	ER25 (2-16)	94	180	51,6	168	65	5,47	
new A63.RAS.E25.95.C80	HSK-A 63	ER25 (2-16)	94	180	51,6	168	80	5,54	
new A100.RAS.E25.95.C80	HSK-A 100	ER25 (2-16)	94	180	51,6	168	80	6,94	
new A100.RAS.E25.95.C110	HSK-A 100	ER25 (2-16)	94	180	51,6	168	110	7,10	
new EP6.RAS.E25.95.C65	EPS 63	ER25 (2-16)	94	152	23,6	168	65	5,46	
new EP6.RAS.E25.95.C80	EPS 63	ER25 (2-16)	94	152	23,6	168	80	5,51	

Zubehör / Accessories / Accessoires / Yedekler



Spannzangen System ER
Collets System ER
Pincés de serrage System ER
Pens ER



Spannmutter ER
Clamping nuts ER
Écrou de serrage ER
Pens kapağı ER



Spannschlüssel ER
Wrench ER
Clé de serrage
Anahtar ER



AA Schlüssel
AA Wrench
Clé AA
AA Anahtar



Winkelköpfe 90° S Typ - ER25 Spannfutter - Drei-Stift Drehmomentarm

Angle Head 90° S Type - ER25 Collet Chuck - Three-pin torque arm

Tête à renvoi d'angle 90° S Type - ER25 Mandrin à pinces -
Bras de couple à trois broches

Açılı Kafa 90° S Tipi - ER25 Pens Başlığı - Üç Pimli Tork Kolu

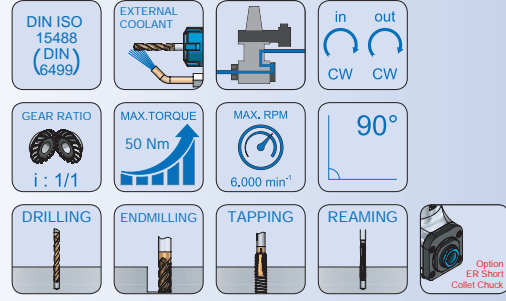
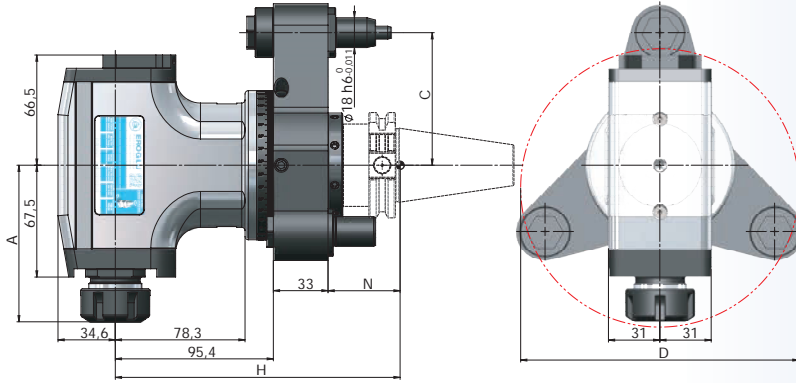

Bestell-Nr. Order Nr. Reference Sipariş Nr.	Kegel Shanks Cônes Konik	Spannbereich Capacity Capacité Kapasite	A	H	N	D	C	Kg	Euro
new 302.RAS.E25.95.C65.3	SK 30	ER25 (2-16)	94	180	51,6	168	65	6,71	
new 402.RAS.E25.95.C65.3	SK 40	ER25 (2-16)	94	180	51,6	168	65	7,22	
new 402.RAS.E25.95.C80.3	SK 40	ER25 (2-16)	94	180	51,6	168	80	7,71	
new 502.RAS.E25.95.C80.3	SK 50	ER25 (2-16)	94	165	36,6	168	80	9,33	
new 502.RAS.E25.95.C110.3	SK 50	ER25 (2-16)	94	165	36,6	168	110	10,56	
new 402ERP.RAS.E25.95.C65.3	SK 40-ERP	ER25 (2-16)	94	180	51,6	168	65	7,25	
new 402ERP.RAS.E25.95.C80.3	SK 40-ERP	ER25 (2-16)	94	180	51,6	168	80	7,73	
new 502ERP.RAS.E25.95.C80.3	SK 50-ERP	ER25 (2-16)	94	165	36,6	168	80	9,37	
new 502ERP.RAS.E25.95.C110.3	SK 50-ERP	ER25 (2-16)	94	165	36,6	168	110	10,60	
new 305.RAS.E25.95.C65.3	BT 30	ER25 (2-16)	94	171	42,6	168	65	6,57	
new 405.RAS.E25.95.C65.3	BT 40	ER25 (2-16)	94	180	51,6	168	65	7,33	
new 405.RAS.E25.95.C80.3	BT 40	ER25 (2-16)	94	180	51,6	168	80	7,81	
new 505.RAS.E25.95.C80.3	BT 50	ER25 (2-16)	94	179,1	50,7	168	80	10,23	
new 505.RAS.E25.95.C110.3	BT 50	ER25 (2-16)	94	179,1	50,7	168	110	11,46	
new 405ERP.RAS.E25.95.C65.3	BT 40-ERP	ER25 (2-16)	94	180	51,6	168	65	7,34	
new 405ERP.RAS.E25.95.C80.3	BT 40-ERP	ER25 (2-16)	94	180	51,6	168	80	7,84	
new 505ERP.RAS.E25.95.C80.3	BT 50-ERP	ER25 (2-16)	94	179,1	50,7	168	80	10,27	
new 505ERP.RAS.E25.95.C110.3	BT 50-ERP	ER25 (2-16)	94	179,1	50,7	168	110	11,50	
new A63.RAS.E25.95.C65.3	HSK-A 63	ER25 (2-16)	94	180	51,6	168	65	6,93	
new A63.RAS.E25.95.C80.3	HSK-A 63	ER25 (2-16)	94	180	51,6	168	80	7,41	
new A100.RAS.E25.95.C80.3	HSK-A 100	ER25 (2-16)	94	180	51,6	168	80	8,81	
new A100.RAS.E25.95.C110.3	HSK-A 100	ER25 (2-16)	94	180	51,6	168	110	10,04	
new EP6.RAS.E25.95.C65.3	EPS 63	ER25 (2-16)	94	152	23,6	168	65	6,90	
new EP6.RAS.E25.95.C80.3	EPS 63	ER25 (2-16)	94	152	23,6	168	80	7,38	

Zubehör / Accessories / Accessoires / Yedekler



Spannzangen System ER
Collets System ER
Pincés de serrage System ER
Pens ER



Spannmutter ER
Clamping nuts ER
Écrou de serrage ER
Pens kapağı ER



Spann Schlüssel ER
Wrench ER
Clé de serrage
Anahtar ER



AA Schlüssel
AA Wrench
Clé AA
AA Anahtar



Winkelköpfe 90° S Typ - KMA16 Quernut-Aufsteckdorne - Standard Drehmomentarm

Angle Head 90° S Type - KMA16 Shell Mill Holder - Standard Torque Arm

Tête à renvoi d'angle 90° S Type - KMA16 Porte-fraises à surfacer -
Bras de couple standard

Açılı Kafa 90° S Tipi - KMA16 Alın Kamalı Malafa - Standart Tork Kolu

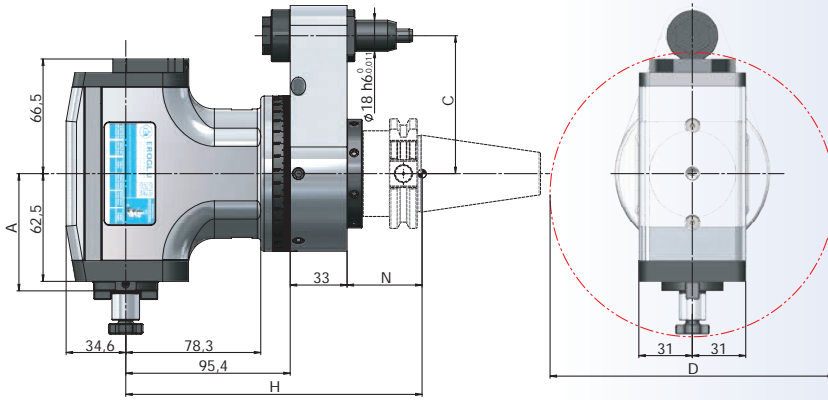

Bestell-Nr. Order Nr. Reference Sipariş Nr.	Kegel Shanks Cônes Konik	Spannbereich Capacity Capacité Kapasite	A	H	N	D	C	Kg	Euro
new 302.RAS.K16.95.C65	SK 30	KMA16	68	180	51,6	165	65	5,15	
new 402.RAS.K16.95.C65	SK 40	KMA16	68	180	51,6	165	65	5,66	
new 402.RAS.K16.95.C80	SK 40	KMA16	68	180	51,6	165	80	5,73	
new 502.RAS.K16.95.C80	SK 50	KMA16	68	165	36,6	165	80	7,36	
new 502.RAS.K16.95.C110	SK 50	KMA16	68	165	36,6	165	110	7,52	
new 402ERP.RAS.K16.95.C65	SK 40-ERP	KMA16	68	180	51,6	165	65	5,69	
new 402ERP.RAS.K16.95.C80	SK 40-ERP	KMA16	68	180	51,6	165	80	5,76	
new 502ERP.RAS.K16.95.C80	SK 50-ERP	KMA16	68	165	36,6	165	80	7,40	
new 502ERP.RAS.K16.95.C110	SK 50-ERP	KMA16	68	165	36,6	165	110	7,56	
new 305.RAS.K16.95.C65	BT 30	KMA16	68	171	42,6	165	65	5,01	
new 405.RAS.K16.95.C65	BT 40	KMA16	68	180	51,6	165	65	5,77	
new 405.RAS.K16.95.C80	BT 40	KMA16	68	180	51,6	165	80	5,84	
new 505.RAS.K16.95.C80	BT 50	KMA16	68	179,1	50,7	165	80	8,26	
new 505.RAS.K16.95.C110	BT 50	KMA16	68	179,1	50,7	165	110	8,42	
new 405ERP.RAS.K16.95.C65	BT 40-ERP	KMA16	68	180	51,6	165	65	5,78	
new 405ERP.RAS.K16.95.C80	BT 40-ERP	KMA16	68	180	51,6	165	80	5,85	
new 505ERP.RAS.K16.95.C80	BT 50-ERP	KMA16	68	179,1	50,7	165	80	8,30	
new 505ERP.RAS.K16.95.C110	BT 50-ERP	KMA16	68	179,1	50,7	165	110	8,46	
new A63.RAS.K16.95.C65	HSK-A 63	KMA16	68	180	51,6	165	65	5,37	
new A63.RAS.K16.95.C80	HSK-A 63	KMA16	68	180	51,6	165	80	5,44	
new A100.RAS.K16.95.C80	HSK-A 100	KMA16	68	180	51,6	165	80	6,84	
new A100.RAS.K16.95.C110	HSK-A 100	KMA16	68	180	51,6	165	110	7,00	
new EP6.RAS.K16.95.C65	EPS 63	KMA16	68	152	23,6	165	65	5,36	
new EP6.RAS.K16.95.C80	EPS 63	KMA16	68	152	23,6	165	80	5,41	

Zubehör / Accessories / Accessoires / Yedekler

DIN 6367



10.45

Fräseranzugsschrauben
Drawn in bolt
Vis de serrage
Alın sıkma civatası



10.44

Mitnehmersteine
Drive keys
Entraîneur
Kama

DIN 6368



10.46

Spannschlüssel für Aufsteckdorne
Wrench
Clé de serrage
Alın civatası sıkma anahtarı



Winkelköpfe 90° S Typ - KMA16 Quernut-Aufsteckdorne - Drei-Stift Drehmomentarm

Angle Head 90° S Type - KMA16 Shell Mill Holder - Three-pin torque arm

Tête à renvoi d'angle 90° S Type - KMA16 Porte-fraises à surfacer -
Bras de couple à trois broches

Açılı Kafa 90° S Tipi - KMA16 Alın Kamalı Malafa - Üç Pimli Tork Kolu

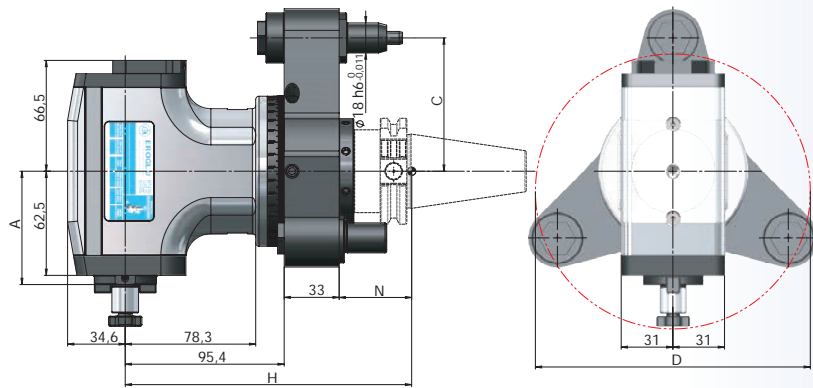

Bestell-Nr. Order Nr. Reference Sipariş Nr.	Kegel Shanks Cônes Konik	Spannbereich Capacity Capacité Kapasite	A	H	N	D	C	Kg	Euro
new 302.RAS.K16.95.C65.3	SK 30	KMA16	68	180	51,6	165	65	6,61	
new 402.RAS.K16.95.C65.3	SK 40	KMA16	68	180	51,6	165	65	7,12	
new 402.RAS.K16.95.C80.3	SK 40	KMA16	68	180	51,6	165	80	7,61	
new 502.RAS.K16.95.C80.3	SK 50	KMA16	68	165	36,6	165	80	9,23	
new 502.RAS.K16.95.C110.3	SK 50	KMA16	68	165	36,6	165	110	10,46	
new 402ERP.RAS.K16.95.C65.3	SK 40-ERP	KMA16	68	180	51,6	165	65	7,15	
new 402ERP.RAS.K16.95.C80.3	SK 40-ERP	KMA16	68	180	51,6	165	80	7,63	
new 502ERP.RAS.K16.95.C80.3	SK 50-ERP	KMA16	68	165	36,6	165	80	9,27	
new 502ERP.RAS.K16.95.C110.3	SK 50-ERP	KMA16	68	165	36,6	165	110	10,50	
new 305.RAS.K16.95.C65.3	BT 30	KMA16	68	171	42,6	165	65	6,47	
new 405.RAS.K16.95.C65.3	BT 40	KMA16	68	180	51,6	165	65	7,23	
new 405.RAS.K16.95.C80.3	BT 40	KMA16	68	180	51,6	165	80	7,71	
new 505.RAS.K16.95.C80.3	BT 50	KMA16	68	179,1	50,7	165	80	10,13	
new 505.RAS.K16.95.C110.3	BT 50	KMA16	68	179,1	50,7	165	110	11,36	
new 405ERP.RAS.K16.95.C65.3	BT 40-ERP	KMA16	68	180	51,6	165	65	7,24	
new 405ERP.RAS.K16.95.C80.3	BT 40-ERP	KMA16	68	180	51,6	165	80	7,77	
new 505ERP.RAS.K16.95.C80.3	BT 50-ERP	KMA16	68	179,1	50,7	165	80	10,17	
new 505ERP.RAS.K16.95.C110.3	BT 50-ERP	KMA16	68	179,1	50,7	165	110	11,40	
new A63.RAS.K16.95.C65.3	HSK-A 63	KMA16	68	180	51,6	165	65	6,83	
new A63.RAS.K16.95.C80.3	HSK-A 63	KMA16	68	180	51,6	165	80	7,31	
new A100.RAS.K16.95.C80.3	HSK-A 100	KMA16	68	180	51,6	165	80	8,71	
new A100.RAS.K16.95.C110.3	HSK-A 100	KMA16	68	180	51,6	165	110	9,94	
new EP6.RAS.K16.95.C65.3	EPS 63	KMA16	68	152	23,6	165	65	6,80	
new EP6.RAS.K16.95.C80.3	EPS 63	KMA16	68	152	23,6	165	80	7,28	

Zubehör / Accessories / Accessoires / Yedekler

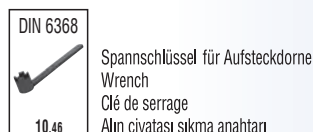



Winkelköpfe 90° M Typ - ER32 Short Spannfutter - Standard Drehmomentarm

Angle Head 90° M Type - ER32 Short Collet Chuck - Standard Torque Arm

Tête à renvoi d'angle 90° M Type - ER32 Short Mandrin à pinces - Bras de couple standard

Açılı Kafa 90° M Tipi - ER32 Short Pens Başlığı - Standart Tork Kolu

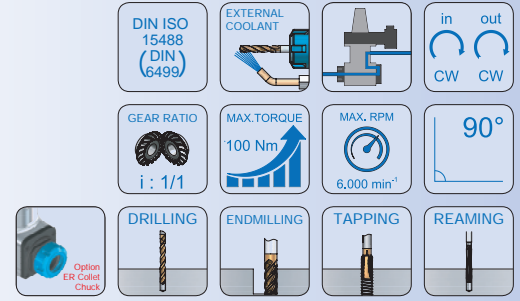
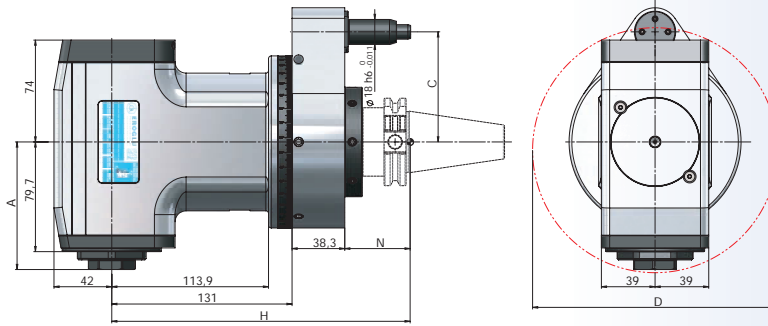

Bestell-Nr. Order Nr. Reference Sipariş Nr.	Kegel Shanks Cônes Konik	Spannbereich Capacity Capacité Kapasite	A	H	N	D	C	Kg	Euro
new 402.RAM.E32S.131.C80	SK 40	ER32S (2-20)	92,7	225	55,7	180	80	10,23	
new 502.RAM.E32S.131.C80	SK 50	ER32S (2-20)	92,7	218	48,7	180	80	12,20	
new 502.RAM.E32S.131.C110	SK 50	ER32S (2-20)	92,7	218	48,7	180	110	12,41	
new 402ERP.RAM.E32S.131.C80	SK 40-ERP	ER32S (2-20)	92,7	225	55,7	180	80	10,26	
new 502ERP.RAM.E32S.131.C80	SK 50-ERP	ER32S (2-20)	92,7	218	48,7	180	80	12,24	
new 502ERP.RAM.E32S.131.C110	SK 50-ERP	ER32S (2-20)	92,7	218	48,7	180	110	12,45	
new 405.RAM.E32S.131.C80	BT 40	ER32S (2-20)	92,7	225	55,7	180	80	10,32	
new 505.RAM.E32S.131.C80	BT 50	ER32S (2-20)	92,7	220	50,7	180	80	12,56	
new 505.RAM.E32S.131.C110	BT 50	ER32S (2-20)	92,7	220	50,7	180	110	12,77	
new 405ERP.RAM.E32S.131.C80	BT 40-ERP	ER32S (2-20)	92,7	225	55,7	180	80	10,33	
new 505ERP.RAM.E32S.131.C80	BT 50-ERP	ER32S (2-20)	92,7	220	50,7	180	80	12,60	
new 505ERP.RAM.E32S.131.C110	BT 50-ERP	ER32S (2-20)	92,7	220	50,7	180	110	12,81	
new A63.RAM.E32S.131.C80	HSK-A 63	ER32S (2-20)	92,7	229	59,7	180	80	10,03	
new A100.RAM.E32S.131.C80	HSK-A 100	ER32S (2-20)	92,7	220	50,7	180	80	11,27	
new A100.RAM.E32S.131.C110	HSK-A 100	ER32S (2-20)	92,7	220	50,7	180	110	11,48	
new EP6.RAM.E32S.131.C80	EPS 63	ER32S (2-20)	92,7	218	48,7	180	80	10,18	

Zubehör / Accessories / Accessoires / Yedekler



Spannzangen System ER
Collets System ER
Pincés de serrage System ER
Pens ER



Spannmutter ER
Clamping nuts ER
Écrou de serrage ER
Pens kapağı ER



Spannschlüssel ER
Wrench ER
Clé de serrage
Anahtar ER



AA Schlüssel
AA Wrench
Clé AA
AA Anahtar

Winkelköpfe 90° M Typ - ER32 Short Spannfutter - Drei-Stift Drehmomentarm



Angle Head 90° M Type - ER32 Short Collet Chuck - Three-Pin Torque Arm

Tête à renvoi d'angle 90° M Type - ER32 Short Mandrin à pinces - Bras de couple à trois broches

Açılı Kafa 90° M Tipi - ER32 Short Pens Başlığı - Üç Pimli Tork Kolu

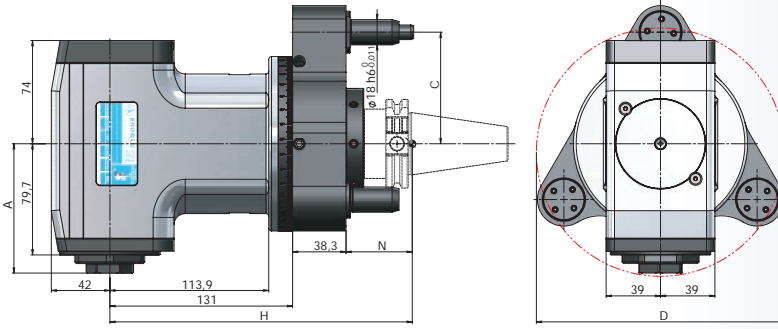
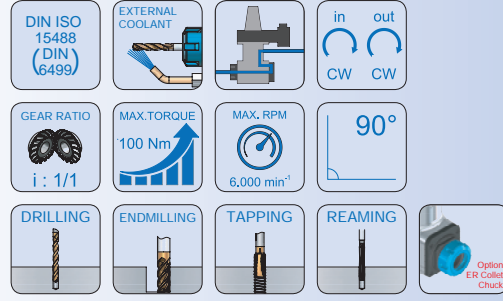

Bestell-Nr. Order Nr. Reference Sipariş Nr.	Kegel Shanks Cônes Konik	Spannbereich Capacity Capacité Kapasite	A	H	N	D	C	Kg	Euro
new 402.RAM.E32S.131.C80.3	SK 40	ER32S (2-20)	92,7	225	55,7	180	80	12,45	
new 502.RAM.E32S.131.C80.3	SK 50	ER32S (2-20)	92,7	218	48,7	180	80	14,42	
new 502.RAM.E32S.131.C110.3	SK 50	ER32S (2-20)	92,7	218	48,7	180	110	16,17	
new 402ERP.RAM.E32S.131.C80.3	SK 40-ERP	ER32S (2-20)	92,7	225	55,7	180	80	12,48	
new 502ERP.RAM.E32S.131.C80.3	SK 50-ERP	ER32S (2-20)	92,7	218	48,7	180	80	14,46	
new 502ERP.RAM.E32S.131.C110.3	SK 50-ERP	ER32S (2-20)	92,7	218	48,7	180	110	16,21	
new 405.RAM.E32S.131.C80.3	BT 40	ER32S (2-20)	92,7	225	55,7	180	80	12,54	
new 505.RAM.E32S.131.C80.3	BT 50	ER32S (2-20)	92,7	220	50,7	180	80	14,78	
new 505.RAM.E32S.131.C110.3	BT 50	ER32S (2-20)	92,7	220	50,7	180	110	16,53	
new 405ERP.RAM.E32S.131.C80.3	BT 40-ERP	ER32S (2-20)	92,7	225	55,7	180	80	12,55	
new 505ERP.RAM.E32S.131.C80.3	BT 50-ERP	ER32S (2-20)	92,7	220	50,7	180	80	14,82	
new 505ERP.RAM.E32S.131.C110.3	BT 50-ERP	ER32S (2-20)	92,7	220	50,7	180	110	16,57	
new A63.RAM.E32S.131.C80.3	HSK-A 63	ER32S (2-20)	92,7	229	59,7	180	80	12,25	
new A100.RAM.E32S.131.C80.3	HSK-A 100	ER32S (2-20)	92,7	220	50,7	180	80	13,49	
new A100.RAM.E32S.131.C110.3	HSK-A 100	ER32S (2-20)	92,7	220	50,7	180	110	15,24	
new EP6.RAM.E32S.131.C80.3	EPS 63	ER32S (2-20)	92,7	218	48,7	180	80	12,40	

Zubehör / Accessories / Accessoires / Yedekler



Spannzangen System ER
Collets System ER
Pincés de serrage System ER
Pens ER



Spannmutter ER
Clamping nuts ER
Écrou de serrage ER
Pens kapağı ER



Spann Schlüssel ER
Wrench ER
Clé de serrage
Anahtar ER



AA Schlüssel
AA Wrench
Clé AA
AA Anahtar



Winkelköpfe 90° M Typ - ER40 Spannfutter - Standard Drehmomentarm

Angle Head 90° M Type - ER40 Collet Chuck - Standard Torque Arm

Tête à renvoi d'angle 90° M Type - ER40 Mandrin à pinces -
Bras de couple standard

Açılı Kafa 90° M Tipi - ER40 Pens Başlığı - Standart Tork Kolu

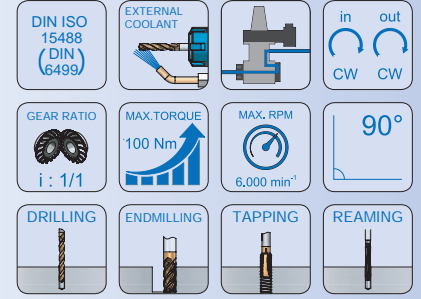
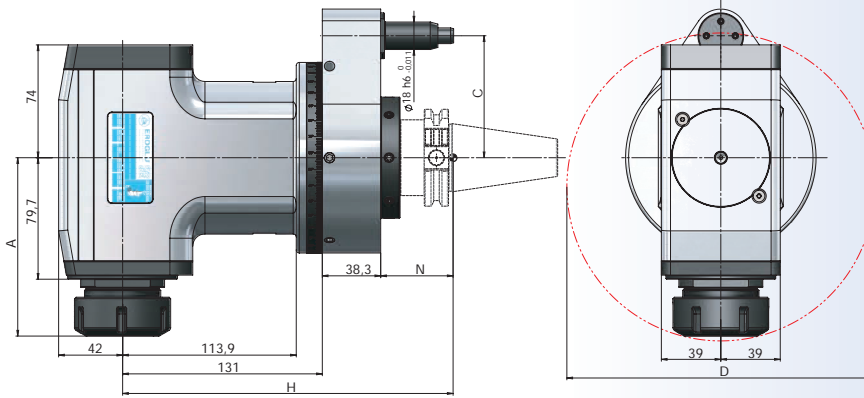

Bestell-Nr. Order Nr. Reference Sipariş Nr.	Kegel Shanks Cônes Konik	Spannbereich Capacity Capacité Kapasite	A	H	N	D	C	Kg	Euro
new 402.RAM.E40.131.C80	SK 40	ER40 (3-26)	117	225	55,7	205	80	10,69	
new 502.RAM.E40.131.C80	SK 50	ER40 (3-26)	117	218	48,7	205	80	12,66	
new 502.RAM.E40.131.C110	SK 50	ER40 (3-26)	117	218	48,7	205	110	12,87	
new 402ERP.RAM.E40.131.C80	SK 40-ERP	ER40 (3-26)	117	225	55,7	205	80	10,72	
new 502ERP.RAM.E40.131.C80	SK 50-ERP	ER40 (3-26)	117	218	48,7	205	80	12,70	
new 502ERP.RAM.E40.131.C110	SK 50-ERP	ER40 (3-26)	117	218	48,7	205	110	12,91	
new 405.RAM.E40.131.C80	BT 40	ER40 (3-26)	117	225	55,7	205	80	10,78	
new 505.RAM.E40.131.C80	BT 50	ER40 (3-26)	117	220	50,7	205	80	13,02	
new 505.RAM.E40.131.C110	BT 50	ER40 (3-26)	117	220	50,7	205	110	13,23	
new 405ERP.RAM.E40.131.C80	BT 40-ERP	ER40 (3-26)	117	225	55,7	205	80	10,79	
new 505ERP.RAM.E40.131.C80	BT 50-ERP	ER40 (3-26)	117	220	50,7	205	80	13,06	
new 505ERP.RAM.E40.131.C110	BT 50-ERP	ER40 (3-26)	117	220	50,7	205	110	13,27	
new A63.RAM.E40.131.C80	HSK-A 63	ER40 (3-26)	117	229	59,7	205	80	10,49	
new A100.RAM.E40.131.C80	HSK-A 100	ER40 (3-26)	117	220	50,7	205	80	11,73	
new A100.RAM.E40.131.C110	HSK-A 100	ER40 (3-26)	117	220	50,7	205	110	11,94	
new EP6.RAM.E40.131.C80	EPS 63	ER40 (3-26)	117	218	48,7	205	80	10,54	

Zubehör / Accessories / Accessoires / Yedekler



Spannzangen System ER
Collets System ER
Pincés de serrage System ER
Pens ER



Spannmutter ER
Clamping nuts ER
Écrou de serrage ER
Pens kapağı ER



Spannschlüssel ER
Wrench ER
Clé de serrage
Anahtar ER



AA Schlüssel
AA Wrench
Clé AA
AA Anahtar



Winkelk pfe 90° M Typ - ER40 Spannfutter - Drei-Stift Drehmomentarm

Angle Head 90° M Type - ER40 Collet Chuck - Three-pin torque arm

T te   renvoi d'angle 90° M Type - ER40 Mandrin   pinces -
Bras de couple   trois broches

Açılı Kafa 90° M Tipi - ER40 Pens Bařlıđı -  ç Pimli Tork Kolu

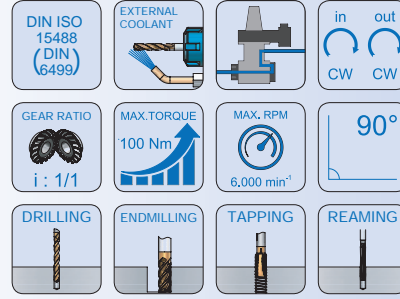
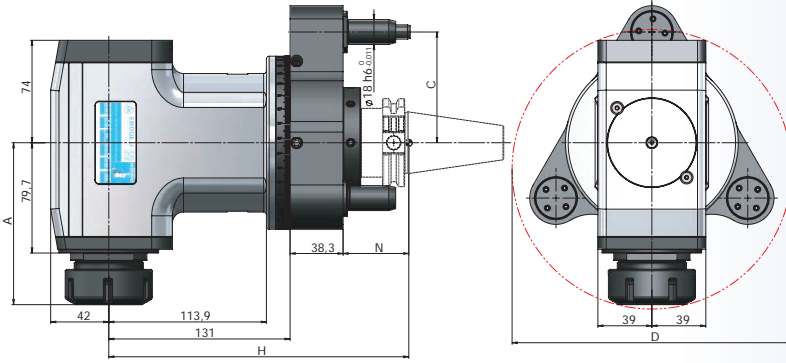

Bestell-Nr. Order Nr. Reference Sipariř Nr.	Kegel Shanks C�nes Konik	Spannbereich Capacity Capacit� Kapasite	A	H	N	D	C	Kg	Euro
new 402.RAM.E40.131.C80.3	SK 40	ER40 (3-26)	117	225	55,7	205	80	12,91	
new 502.RAM.E40.131.C80.3	SK 50	ER40 (3-26)	117	218	48,7	205	80	14,88	
new 502.RAM.E40.131.C110.3	SK 50	ER40 (3-26)	117	218	48,7	205	110	16,63	
new 402ERP.RAM.E40.131.C80.3	SK 40-ERP	ER40 (3-26)	117	225	55,7	205	80	12,94	
new 502ERP.RAM.E40.131.C80.3	SK 50-ERP	ER40 (3-26)	117	218	48,7	205	80	14,92	
new 502ERP.RAM.E40.131.C110.3	SK 50-ERP	ER40 (3-26)	117	218	48,7	205	110	16,67	
new 405.RAM.E40.131.C80.3	BT 40	ER40 (3-26)	117	225	55,7	205	80	13,00	
new 505.RAM.E40.131.C80.3	BT 50	ER40 (3-26)	117	220	50,7	205	80	15,24	
new 505.RAM.E40.131.C110.3	BT 50	ER40 (3-26)	117	220	50,7	205	110	16,99	
new 405ERP.RAM.E40.131.C80.3	BT 40-ERP	ER40 (3-26)	117	225	55,7	205	80	13,01	
new 505ERP.RAM.E40.131.C80.3	BT 50-ERP	ER40 (3-26)	117	220	50,7	205	80	15,28	
new 505ERP.RAM.E40.131.C110.3	BT 50-ERP	ER40 (3-26)	117	220	50,7	205	110	17,03	
new A63.RAM.E40.131.C80.3	HSK-A 63	ER40 (3-26)	117	229	59,7	205	80	12,71	
new A100.RAM.E40.131.C80.3	HSK-A 100	ER40 (3-26)	117	220	50,7	205	80	13,95	
new A100.RAM.E40.131.C110.3	HSK-A 100	ER40 (3-26)	117	220	50,7	205	110	15,70	
new EP6.RAM.E40.131.C80.3	EPS 63	ER40 (3-26)	117	218	48,7	205	80	12,86	

Zubeh r / Accessories / Accessoires / Yedekler



Spannzangen System ER
Collets System ER
Pinces de serrage System ER
Pens ER



Spannmutter ER
Clamping nuts ER
 crou de serrage ER
Pens kapađı ER



Spannchl ssel ER
Wrench ER
Cl  de serrage
Anahtar ER



AA Schl ssel
AA Wrench
Cl  AA
AA Anahtar



Winkelköpfe 90° M Typ - ISO30 Adapter / Reduzierungen- Standard Drehmomentarm

Angle Head 90° M Type - ISO30 Reduction Sleeves - Standard Torque Arm

Tête à renvoi d'angle 90° M Type - ISO30 Douilles de Réduction -
Bras de couple standard

Açılı Kafa 90° M Tipi - ISO30 Çektirme Civatalı Redüksiyon - Standart Tork Kolu

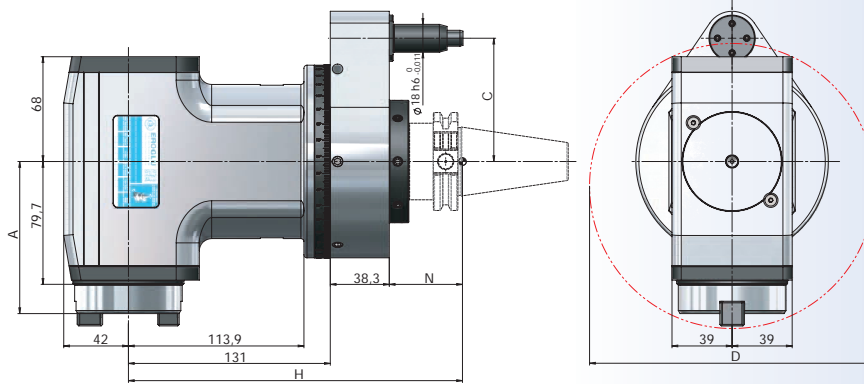

Bestell-Nr. Order Nr. Reference Sipariş Nr.	Kegel Shanks Cônes Konik	Spannbereich Capacity Capacité Kapasite	A	H	N	D	C	Kg	Euro
new 402.RAM.I30.131.C80	SK 40	ISO30	98,7	225	55,7	185	80	10,43	
new 502.RAM.I30.131.C80	SK 50	ISO30	98,7	218	48,7	185	80	12,40	
new 502.RAM.I30.131.C110	SK 50	ISO30	98,7	218	48,7	185	110	12,61	
new 402ERP.RAM.I30.131.C80	SK 40-ERP	ISO30	98,7	225	55,7	185	80	10,46	
new 502ERP.RAM.I30.131.C80	SK 50-ERP	ISO30	98,7	218	48,7	185	80	12,44	
new 502ERP.RAM.I30.131.C110	SK 50-ERP	ISO30	98,7	218	48,7	185	110	12,65	
new 405.RAM.I30.131.C80	BT 40	ISO30	98,7	225	55,7	185	80	10,52	
new 505.RAM.I30.131.C80	BT 50	ISO30	98,7	220	50,7	185	80	12,76	
new 505.RAM.I30.131.C110	BT 50	ISO30	98,7	220	50,7	185	110	12,97	
new 405ERP.RAM.I30.131.C80	BT 40-ERP	ISO30	98,7	225	55,7	185	80	10,53	
new 505ERP.RAM.I30.131.C80	BT 50-ERP	ISO30	98,7	220	50,7	185	80	12,80	
new 505ERP.RAM.I30.131.C110	BT 50-ERP	ISO30	98,7	220	50,7	185	110	13,01	
new A63.RAM.I30.131.C80	HSK-A 63	ISO30	98,7	229	59,7	185	80	10,23	
new A100.RAM.I30.131.C80	HSK-A 100	ISO30	98,7	220	50,7	185	80	11,47	
new A100.RAM.I30.131.C110	HSK-A 100	ISO30	98,7	220	50,7	185	110	11,68	
new EP6.RAM.I30.131.C80	EPS 63	ISO30	98,7	218	48,7	185	80	10,28	



Winkelköpfe 90° M Typ - ISO30 Adapter / Reduzierungen- Drei-Stift Drehmomentarm

Angle Head 90° M Type - ISO30 Reduction Sleeves - Three-pin torque arm

Tête à renvoi d'angle 90° M Type - ISO30 Douilles de Réduction -
Bras de couple à trois broches

Açılı Kafa 90° M Tipi - ISO30 Çektirme Civatalı Redüksiyon - Üç Pimli Tork Kolu

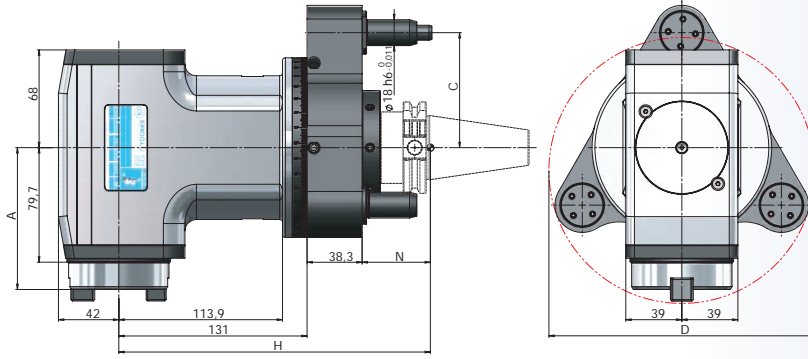

Bestell-Nr. Order Nr. Reference Sipariş Nr.	Kegel Shanks Cônes Konik	Spannbereich Capacity Capacité Kapasite	A	H	N	D	C	Kg	Euro
new 402.RAM.I30.131.C80.3	SK 40	ISO30	98,7	225	55,7	185	80	12,65	
new 502.RAM.I30.131.C80.3	SK 50	ISO30	98,7	218	48,7	185	80	14,62	
new 502.RAM.I30.131.C110.3	SK 50	ISO30	98,7	218	48,7	185	110	16,37	
new 402ERP.RAM.I30.131.C80.3	SK 40-ERP	ISO30	98,7	225	55,7	185	80	12,68	
new 502ERP.RAM.I30.131.C80.3	SK 50-ERP	ISO30	98,7	218	48,7	185	80	14,66	
new 502ERP.RAM.I30.131.C110.3	SK 50-ERP	ISO30	98,7	218	48,7	185	110	16,41	
new 405.RAM.I30.131.C80.3	BT 40	ISO30	98,7	225	55,7	185	80	12,74	
new 505.RAM.I30.131.C80.3	BT 50	ISO30	98,7	220	50,7	185	80	14,98	
new 505.RAM.I30.131.C110.3	BT 50	ISO30	98,7	220	50,7	185	110	16,73	
new 405ERP.RAM.I30.131.C80.3	BT 40-ERP	ISO30	98,7	225	55,7	185	80	12,75	
new 505ERP.RAM.I30.131.C80.3	BT 50-ERP	ISO30	98,7	220	50,7	185	80	15,02	
new 505ERP.RAM.I30.131.C110.3	BT 50-ERP	ISO30	98,7	220	50,7	185	110	16,77	
new A63.RAM.I30.131.C80.3	HSK-A 63	ISO30	98,7	229	59,7	185	80	12,45	
new A100.RAM.I30.131.C80.3	HSK-A 100	ISO30	98,7	220	50,7	185	80	13,69	
new A100.RAM.I30.131.C110.3	HSK-A 100	ISO30	98,7	220	50,7	185	110	15,44	
new EP6.RAM.I30.131.C80.3	EPS 63	ISO30	98,7	218	48,7	185	80	12,60	



Winkelköpfe 90° M Typ - KMA22 Quernut-Aufsteckdorne - Standard Drehmomentarm

Angle Head 90° M Type - KMA22 Shell Mill Holder - Standard Torque Arm

Tête à renvoi d'angle 90° M Type - KMA22 Porte-fraises à surfacier -
Bras de couple standard

Açılı Kafa 90° M Tipi - KMA22 Alın Kamalı Malafa - Standart Tork Kolu

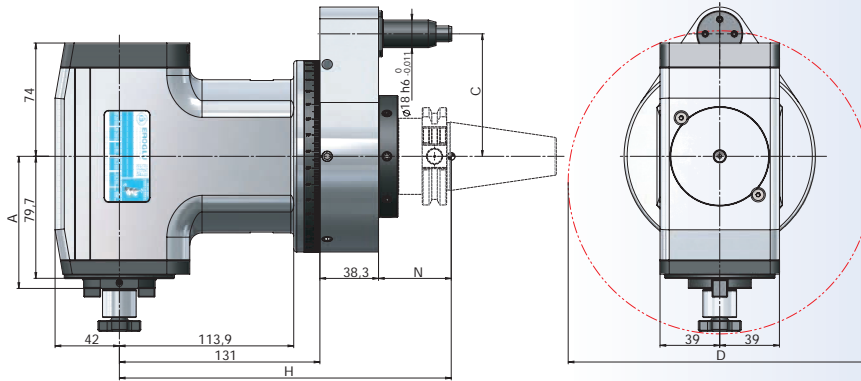

Bestell-Nr. Order Nr. Reference Sipariş Nr.	Kegel Shanks Cônes Konik	Spannbereich Capacity Capacité Kapasite	A	H	N	D	C	Kg	Euro
new 402.RAM.K22.131.C80	SK 40	KMA22	86,3	225	55,7	201	80	10,50	
new 502.RAM.K22.131.C80	SK 50	KMA22	86,3	218	48,7	201	80	12,47	
new 502.RAM.K22.131.C110	SK 50	KMA22	86,3	218	48,7	201	110	12,68	
new 402ERP.RAM.K22.131.C80	SK 40-ERP	KMA22	86,3	225	55,7	201	80	10,53	
new 502ERP.RAM.K22.131.C80	SK 50-ERP	KMA22	86,3	218	48,7	201	80	12,51	
new 502ERP.RAM.K22.131.C110	SK 50-ERP	KMA22	86,3	218	48,7	201	110	12,72	
new 405.RAM.K22.131.C80	BT 40	KMA22	86,3	225	55,7	201	80	10,59	
new 505.RAM.K22.131.C80	BT 50	KMA22	86,3	220	50,7	201	80	12,83	
new 505.RAM.K22.131.C110	BT 50	KMA22	86,3	220	50,7	201	110	13,04	
new 405ERP.RAM.K22.131.C80	BT 40-ERP	KMA22	86,3	225	55,7	201	80	10,60	
new 505ERP.RAM.K22.131.C80	BT 50-ERP	KMA22	86,3	220	50,7	201	80	12,87	
new 505ERP.RAM.K22.131.C110	BT 50-ERP	KMA22	86,3	220	50,7	201	110	13,08	
new A63.RAM.K22.131.C80	HSK-A 63	KMA22	86,3	229	59,7	201	80	10,30	
new A100.RAM.K22.131.C80	HSK-A 100	KMA22	86,3	220	50,7	201	80	11,54	
new A100.RAM.K22.131.C110	HSK-A 100	KMA22	86,3	220	50,7	201	110	11,75	
new EP6.RAM.K22.131.C80	EPS 63	KMA22	86,3	218	48,7	201	80	10,35	

Zubehör / Accessories / Accessoires / Yedekler

DIN 6367



Fräseranzugsschrauben
Drawn in bolt
Vis de serrage
Alın sıkma civatası

10.45



Mitnehmersteine
Drive keys
Entraîneur
Kama

10.44

DIN 6368



Spannschlüssel für Aufsteckdorne
Wrench
Clé de serrage
Alın civatası sıkma anahtarı

10.46



Winkelköpfe 90° M Typ - KMA22 Quernut-Aufsteckdorne - Drei-Stift Drehmomentarm

Angle Head 90° M Type - KMA22 Shell Mill Holder - Three-pin torque arm

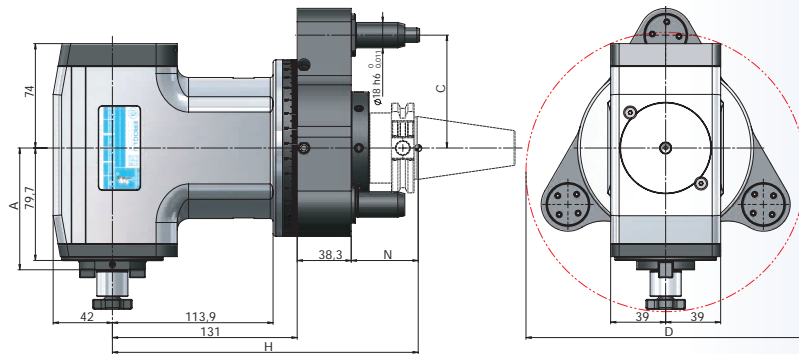

Tête à renvoi d'angle 90° M Type - KMA22 Porte-fraises à surfacer -
Bras de couple à trois broches

Açılı Kafa 90° M Tipi - KMA22 Alın Kamalı Malafa - Üç Pimli Tork Kolu



Bestell-Nr. Order Nr. Reference Sipariş Nr.	Kegel Shanks Cônes Konik	Spannbereich Capacity Capacité Kapasite	A	H	N	D	C	Kg	Euro
new 402.RAM.K22.131.C80.3	SK 40	KMA22	86,3	225	55,7	201	80	12,72	
new 502.RAM.K22.131.C80.3	SK 50	KMA22	86,3	218	48,7	201	80	14,69	
new 502.RAM.K22.131.C110.3	SK 50	KMA22	86,3	218	48,7	201	110	16,44	
new 402ERP.RAM.K22.131.C80.3	SK 40-ERP	KMA22	86,3	225	55,7	201	80	12,75	
new 502ERP.RAM.K22.131.C80.3	SK 50-ERP	KMA22	86,3	218	48,7	201	80	14,73	
new 502ERP.RAM.K22.131.C110.3	SK 50-ERP	KMA22	86,3	218	48,7	201	110	16,48	
new 405.RAM.K22.131.C80.3	BT 40	KMA22	86,3	225	55,7	201	80	12,81	
new 505.RAM.K22.131.C80.3	BT 50	KMA22	86,3	220	50,7	201	80	15,05	
new 505.RAM.K22.131.C110.3	BT 50	KMA22	86,3	220	50,7	201	110	16,80	
new 405ERP.RAM.K22.131.C80.3	BT 40-ERP	KMA22	86,3	225	55,7	201	80	12,82	
new 505ERP.RAM.K22.131.C80.3	BT 50-ERP	KMA22	86,3	220	50,7	201	80	15,09	
new 505ERP.RAM.K22.131.C110.3	BT 50-ERP	KMA22	86,3	220	50,7	201	110	16,84	
new A63.RAM.K22.131.C80.3	HSK-A 63	KMA22	86,3	229	59,7	201	80	12,52	
new A100.RAM.K22.131.C80.3	HSK-A 100	KMA22	86,3	220	50,7	201	80	13,76	
new A100.RAM.K22.131.C110.3	HSK-A 100	KMA22	86,3	220	50,7	201	110	15,51	
new EP6.RAM.K22.131.C80.3	EPS 63	KMA22	86,3	218	48,7	201	80	12,67	

Zubehör / Accessories / Accessoires / Yedekler

 DIN 6367 Fräseranzugsschrauben Drawn in bolt Vis de serrage Alın sıkma civatası 10.45	 DIN 6368 Mitnehmersteine Drive keys Entraîneur Kama 10.44	 DIN 6368 Spannschlüssel für Aufsteckdorne Wrench Clé de serrage Alın civatası sıkma anahtarı 10.46
---	---	--

